



Our Superconducting Fault Current Limiter

A safe, robust, cost-effective and ultra-fast protection technology

Our superconducting fault current limiter (SFCL) technology provides an ultra-fast passive response to prevent the propagation of high over-voltages in your networks.

OUR SFCL TECHNOLOGY

High Temperature Cryogenic Operation

Our SFCL prototype operates at around 70 K in a liquid nitrogen bath. This cryogenic process is:



Easy to manage



Eco-friendly



Widely used

in food, chemical and pharmaceutical industries...

Innovative Design

- Compact non-inductive pancake coil
- Scalability from medium voltage (MV) to high voltage (HV) applications, from 5kV to 525kV
- Simple to integrate into your system

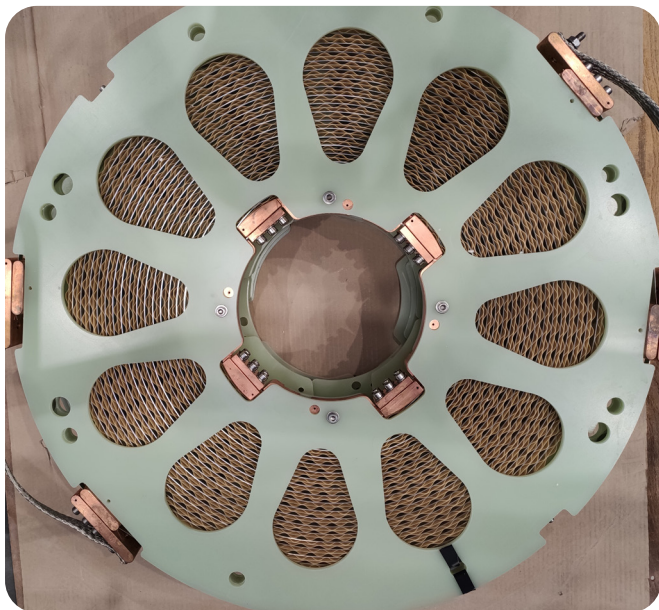

Pancake coil made of wound superconductor tape

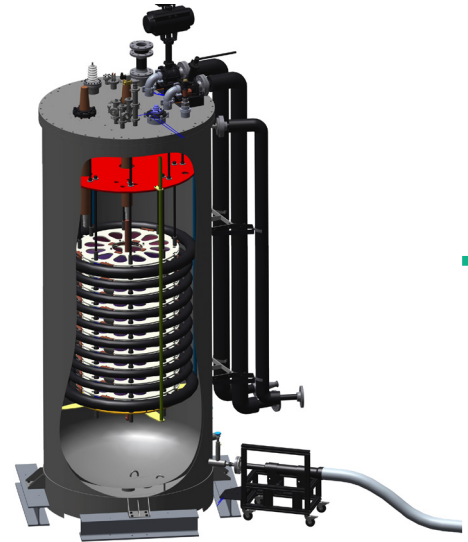

SUPERGRID INSTITUTE: YOUR PARTNER OF CHOICE

Why should you partner with us to develop your future superconducting fault current limiter solutions?

Expertise

We are widely recognised for our exceptional design capabilities in the fields of high power & high voltage apparatus, as well as our expertise in AC and DC grid simulation.

State of the art testing facilities

Our short circuit test and dielectric test laboratories are at your disposition to deliver fast results.

Proven References

Successful results on SFCL technologies in European projects such as:

FastGrid

SCARLET
Superconducting CABLES for sustainable Energy Transition

This project has received funding from the European Union's Horizon 2020 and Horizon Europe research and innovation programmes

APPLICATION CASES

A safe, robust, cost-effective and ultra-fast protection technology

AC grids: higher power, same protection equipment

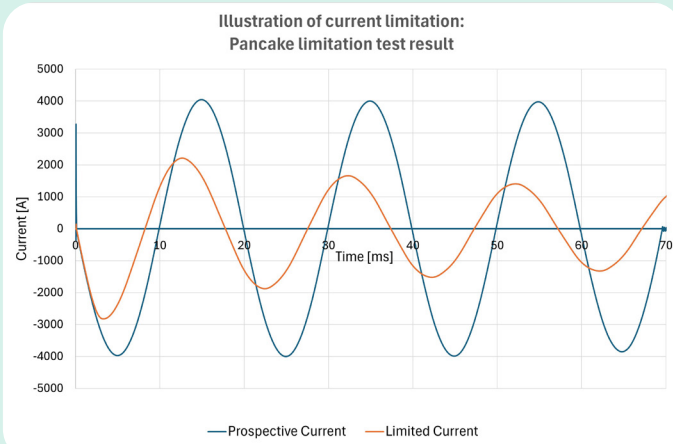

Current limitation achieved using the SFCL.

The SFCL relieves congestion on your AC network by limiting short circuit currents in your substation without upgrading your existing switchyard.

Offshore applications: Ideal compact design

Residual current breaker if needed

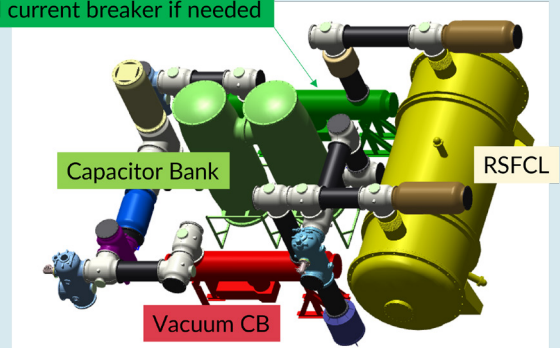

GIS layout using approximately 165 m² (including 1 m clearance).

Reduce the overall footprint of your offshore DC protection equipment by 40 to 50% by incorporating an SFCL into your gas-insulated switchgear coupled with a mechanical DC circuit breaker.

MTDC Grids: a cost-effective protection alternative

Protection device ready to implement into new HVDC networks up to 525 kV_{DC} / 2000 A.

- **Selective strategy:** Allows for selective fault management.
- **Converter protection:** no additional inductance needed; prevents current blocking by the converter.

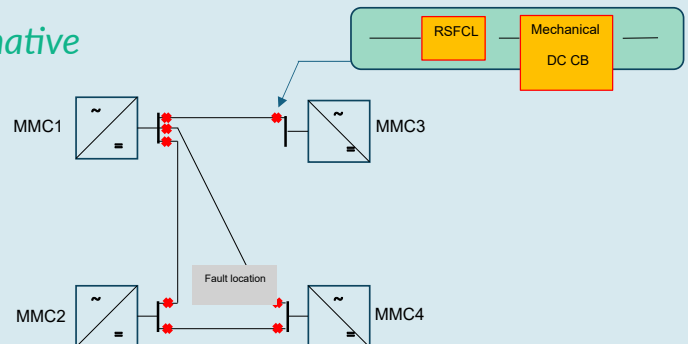

SFCL in a multi-terminal electrical diagram

BECOME OUR PARTNER IN INNOVATION

SuperGrid Institute is seeking industrial partners to further develop and implement our revolutionary SFCL technology.

Gain time in bringing your product to the market by working with us!

BOOK A FREE DEMO